



磁立方

# SPECIFICATION FOR APPROVAL

**CUSTOMER** : \_\_\_\_\_

**CUSTOMER P/N** : \_\_\_\_\_

**DESCRIPTION** : Common Mode Line Filter

**Supplier P/N** : LFET2725W-151P

**REVISION NO.** : V2.0

**DATE** : 2021-Dec-02

**NOTES** : STANDARD

Supplier DOCUMENTED	
APPROVED	David
CHECKED	Zhao yun
PREPARED	You yuan

CUSTOMER APPROVAL	

© Company seals

Version:2.0	CUSTOMER P/N		PRODUCT	Common Mode Line Filter
	ITEM P/N	LFET2725W-151P	DATE	2021-Dec-02



深圳市磁立方科技有限公司  
ShenZhen Magnetic Cube Technology Co., LTD.

TEL:0755-23018051 E-FAX:0755-22140304 E-MAIL:Sales@mct8.com HTTP:www.mct8.com  
ADD:F2, Building C, Furong Road No.8 , Tantou, Songgang, Baoan District, Shenzhen



# MAIN SPECIFICATION

## EXPLANATION OF PART NUMBERS

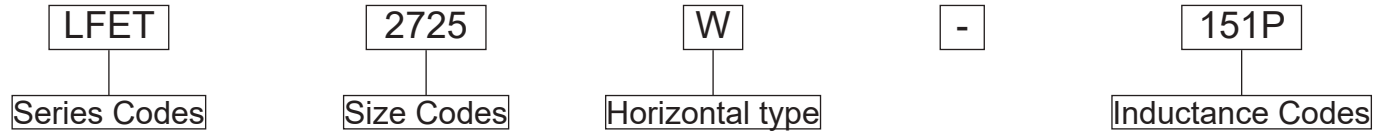

## Schematic:

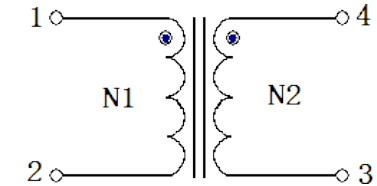

## PRODUCT DIMENSIONS (mm)

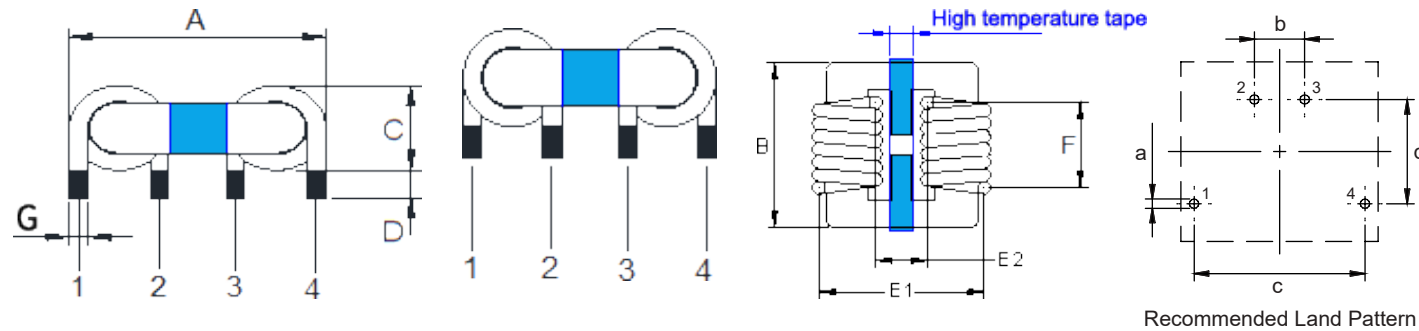

<b>A</b>	27.5Max	<b>F</b>	14.5±0.5
<b>B</b>	25.0Max	<b>G</b>	Ø1.8±0.1
<b>C</b>	11.3Max	<b>a</b>	Φ2.1
<b>D</b>	4.5±0.5	<b>b</b>	6.2
<b>E1</b>	24.6±0.5	<b>c</b>	24.6
<b>E2</b>	6.2±0.5	<b>d</b>	14.5

## ELECTRICAL CHARACTERISTICS

ITEM P/N	@ 25 ± 5°C Ambient Temperature				DCR @ 25°C R(1-2), R(3-4) (mΩ)
	INDUCTANCE (Test condition: 10KHz, 0.1V)		I <sub>rms</sub> (1-4) (2-3short circuit) Δ T=60°C	HI-POT(N1-N2) 50Hz/5mA/2sec	
	Lo(1-2)&Lo(4-3) (μH)	Lk(1-2) (3-4short circuit)(μH)			
LFET2725W-151P	150±40%	5.6Typ.	20Max	1500V(AC)	1.9Max

- ◎ All test data is referenced to 25°C ambient.
- ◎ I<sub>rms</sub>: DC current(A) that will cause an approximate Δ T of 40°C .
- ◎ Isat: DC current(A) that will cause Lo to drop approximate 30%.
- ◎ Operating temperature range is -25°C to 125°C .
- ◎ The part temperature(ambient and temp rise) should not exceed 125°C under worse case operating conditions. Circuit design, component placement, PWB trace size and thickness, airflow and other cooling provision all affect the part temperature. Part temperature should be verified in the end application.

Version:2.0	CUSTOMER P/N	PRODUCT	Common Mode Line Filter
	ITEM P/N	DATE	2021-Dec-02

 深圳市磁立方科技有限公司 TEL:0755-23018051 E-FAx:0755-22140304 E-MAIL:Sales@mct8.com HTTP:www.mct8.com  
ShenZhen Magnetic Cube Technology Co., LTD. ADD:F2, Building C, Furong Road No.8 , Tantou, Songgang, Baoan District, Shenzhen



# CHARACTERISTICS

Typical Insertion Loss:

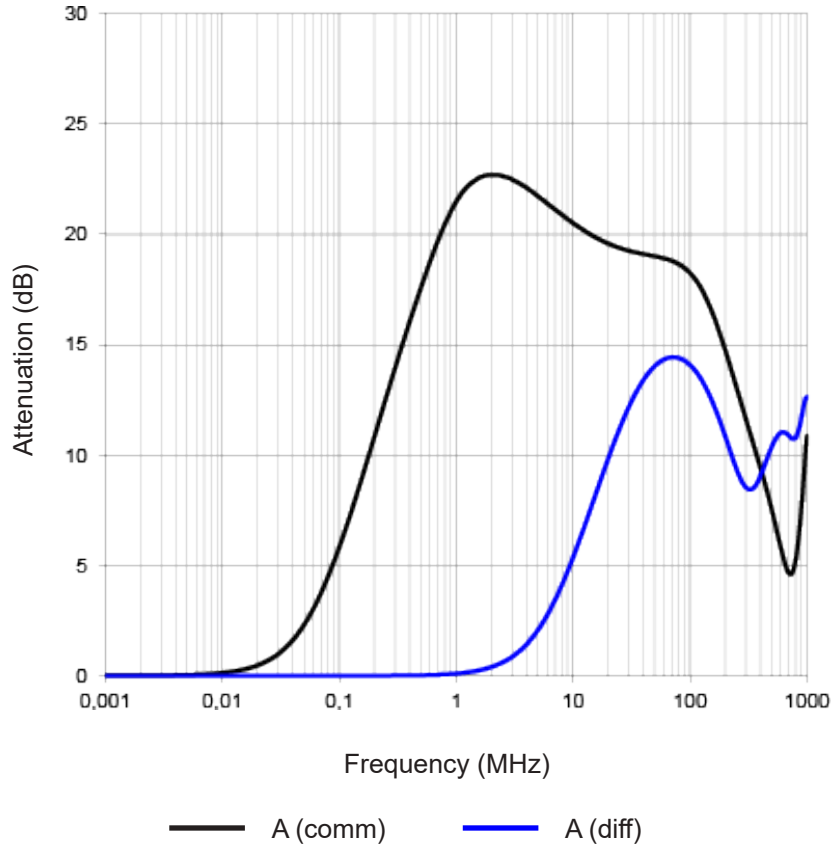

Typical Impedance Characteristics:

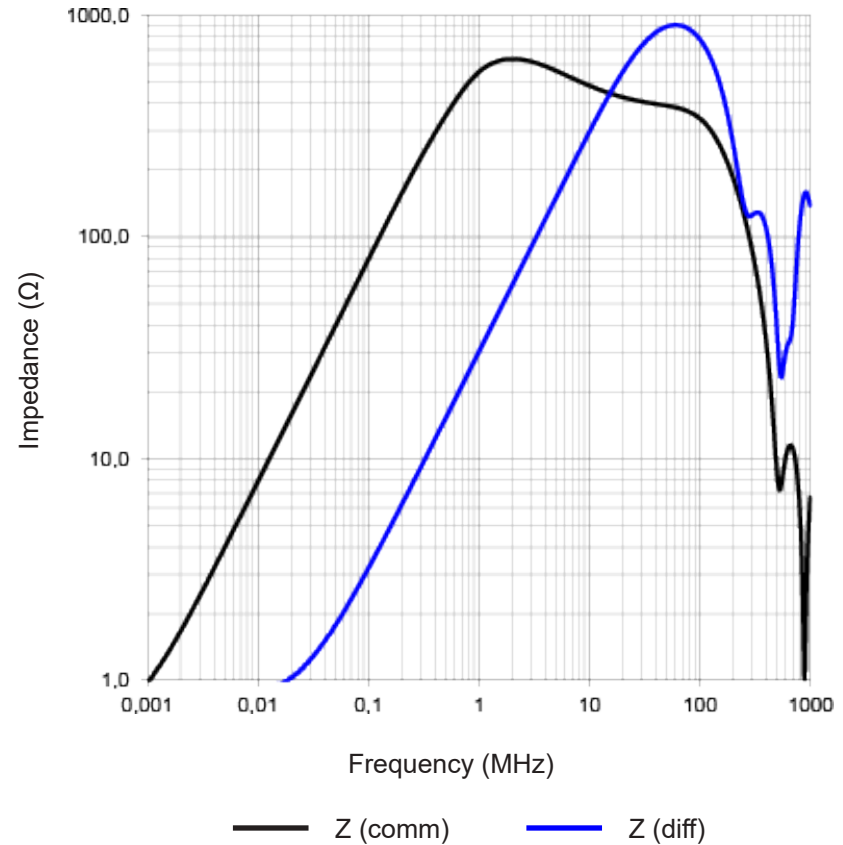

Version:2.0	CUSTOMER P/N	LFET2725W-151P	PRODUCT	Common Mode Line Filter
	ITEM P/N		DATE	2021-Dec-02



深圳市磁立方科技有限公司  
ShenZhen Magnetic Cube Technology Co., LTD.

TEL:0755-23018051 E-FAX:0755-22140304 E-MAIL:Sales@mct8.com HTTP:www.mct8.com  
ADD:F2, Building C, Furong Road No.8 , Tantou, Songgang, Baoan District, Shenzhen



# CHARACTERISTICS

## RECOMMENDED SOLDERING TEMP. GRAPH



A	B	C	D	E
260°C	230°C	8-10Sec	150°C	60~240Sec

## MECHANICAL RELIABILITY

TEST	Specification & Requirement	Method Used
Solderability	The surface of terminal/pin tested shall be covered with new solder by 95%	Solder heat proof.
		Preheating: 180 ±10°C 90 seconds
		Soldering: 255 ±5°C for 3 ±1 sec
Shock	Inductance change within ± 5% Without mechanical damage	Drop down with 981m/s <sup>2</sup> (100G) shock
		Attitude upon a rubber block method shock testing machine, 3 tests.
Vibration	Inductance change within ± 5% Without mechanical damage	Vibration frequency: 10Hz to 55Hz to 10Hz, 60 seconds cycle.
		Vibration time: 2 hours

## ENDURANCE RELIABILITY

TEST	Specification & Requirement	Method Used
Thermal Shock	Inductance change within ± 5% Without mechanical damage	-25°C ,(30 mins) -> room temp. (5 mins) ->125°C , (30 mins) -> room temp. (5 mins) 100 cycles
Heat Resistance	Inductance change within ± 5% Without mechanical damage	Apply IDC current @ 85°C ambient Duration: 1000 hrs
Humidity Resistance	Inductance change within ± 5% Without mechanical damage	Apply IDC current @ 60°C ambient Humidity: 90~95% Duration: 1000 hrs
Low Temp. Storing	Inductance change within ± 5% Without mechanical damage	Storing Temp -25 ±2 °C for total 1,000 +4/-0 hours
High Temp. Storing	Inductance change within ± 5% Without mechanical damage	Storing Temp 125±2 °C for total 1,000 +4/-0 hours

Version:2.0	CUSTOMER P/N	LFET2725W-151P	PRODUCT	Common Mode Line Filter
	ITEM P/N		DATE	2021-Dec-02



深圳市磁立方科技有限公司  
ShenZhen Magnetic Cube Technology Co., LTD.

TEL:0755-23018051 E-FAX:0755-22140304 E-MAIL:Sales@mct8.com HTTP:www.mct8.com  
ADD:F2, Building C, Furong Road No.8 , Tantou, Songgang, Baoan District, Shenzhen



# PACKING INFORMATION

## PACKING INFORMATION Unit : (mm)

- I.The product model, name, quantity, production cycle, factory date, manufacturer's logo and QA factory inspection seal are marked on the packaging box.
- II.One bundle per carton, 7 layers per bundle, 30pcs per layer. The number of packages per carton is 210PCS.
- III.The same product with different production cycles shall not be put into the same packing box.

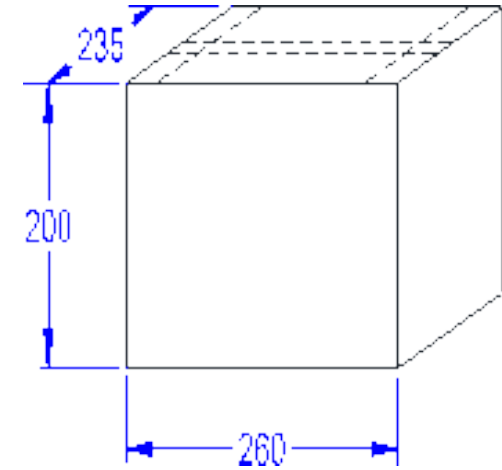
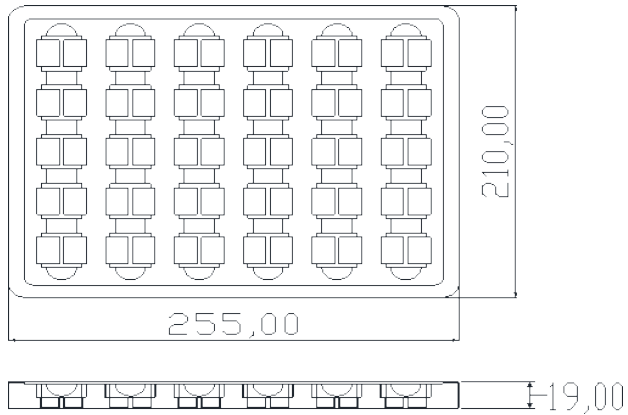

PVC SIZE	QUANTITY
255*210*19mm	30/PVC

OUTBOX SIZE	QUANTITY
260*235*200mm	210PCS/BOX

Version:2.0	CUSTOMER P/N		PRODUCT	Common Mode Line Filter
	ITEM P/N	LFET2725W-151P	DATE	2021-Dec-02



**深圳市磁立方科技有限公司**  
ShenZhen Magnetic Cube Technology Co., LTD.

TEL:0755-23018051 E-FAI:0755-22140304 E-MAIL:Sales@mct8.com HTTP:www.mct8.com  
ADD:F2, Building C, Furong Road No.8 , Tantou, Songgang, Baoan District, Shenzhen

